



Maximum Performance



UY800, UY1000, UY1200

FEATURES AND BENEFITS

- Freestanding, high spin
- Stainless steel cabinet (AISI 304)
- Stainless steel drum and tub
- Extra large door opening (UY800, UY1000 Ø 530 mm, UY1200 Ø 650 mm)
- Two large drain valves (Ø 103 mm)
- Easy access to all parts
- Standard liquid soap connections
- Frequency controlled motor
- Perforated lifting ribs: more mechanical action, lower water consumption
- Air operated water inlet
- Ecological washing programmes
 - significantly reduces water and electricity consumption
- Patented soap dispenser with 5 removable compartments
- Liquid soap connection : automatic dosing
- Manual weighing system

OPTIONS

- Liquid soap pumps
- Recycle drain valve
- Insulation for energy, heat & noise reduction
- Automatic weighing system through 4 weighing cells
- Tilting system : assists operators during loading & unloading

CONTROL

- UniLinc Touch
 - 7" full color touch screen display with swipe function: very intuitive for users
 - user-friendly screen with operating instructions built in as part of the control
 - Complete control content available in 34 languages
 - 20 standard wash programmes, total memory capacity for 99 programmes
 - Automated service reminders remind users to maintenance tasks
 - Water leak detection
 - Slow drain detection
 - Temperature-time verification

HIGH SPIN INDUSTRIAL WASHER EXTRACTORS

TYPE		UY800	UY1000	UY1200
INNERDRUM				
Capacity (1:10)	kg/lb	80/180	100/230	120/275
Capacity (1:9)	kg/lb	89 / 196	108 / 238	128 / 282
Volume	l	807	972	1154
Diameter	mm	1110	1200	1300
MOTOR				
Frequency controlled		Standard	Standard	Standard
DRUM SPEED				
Wash	rpm	36	33	32
Extraction	rpm	750	720	695
G-Factor		350	350	350
CABINET				
Stainless steel		Standard	Standard	Standard
DRUM				
Stainless steel		Standard	Standard	Standard
HEATING				
Electrical (standard)	kW	67.5/70	-	-
Steam high pressure	bar	3-8	3-8	3-8
CONNECTION				
Electrical	kW		3x380-480V 50/60Hz 3x208-240V 50/60Hz	
Water inlet	inch	3x1 1/2"	3x1 1/2"	3x1 1/2"
Steam inlet	inch	1"	1"	1"
Compressed air inlet	Ø mm	8	8	8
Drain	mm	2x103	2x103	2x103
DIMENSIONS				
HxWxD	mm	1985x1495x1940	2060x1790x2005	2085x1855x2085
TRANSPORT DATA				
Gross weight	kg	2830	3410	3710
Net weight	kg	2640	3170	3480
Volume (packed)	m ³	7.25	9.29	10.16
Crate packing HxWxD	mm	2200x1690x1950	2345x1865x2125	2340x2000x2170

- = Not available

Standard = Standard execution, The data concerning dimensions of machines include all extended parts

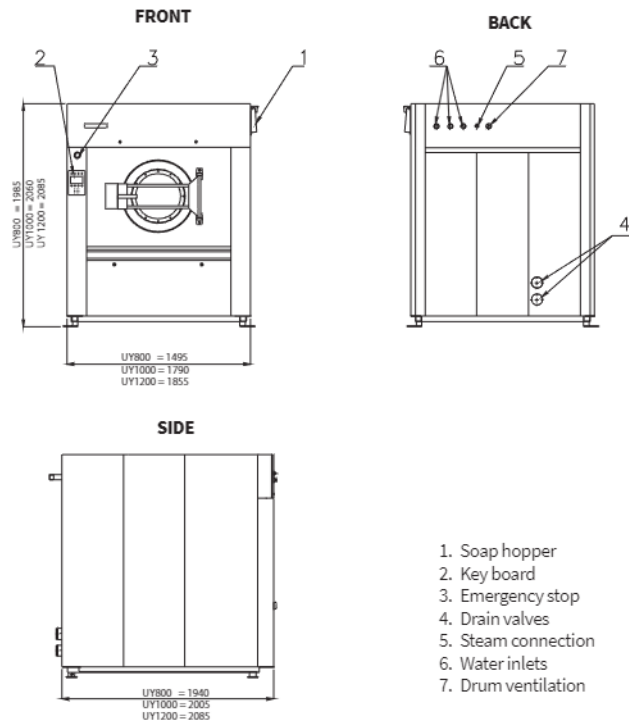

1. Soap hopper
2. Key board
3. Emergency stop
4. Drain valves
5. Steam connection
6. Water inlets
7. Drum ventilation

TO LEARN MORE, OR TO FIND A DISTRIBUTOR IN YOUR AREA, VISIT UNIMAC.COM
ALLIANCE LAUNDRY SYSTEMS - SHEPARD ST, RIPON WI 54971 - +1 800 587 5458

Consult your UniMac® distributor for details. For the most accurate information, the installation guide should be used for all design and construction purposes. Due to continuous product improvements, design and specifications subject to change without notice. The quality management systems at Alliance Laundry Systems' Ripon facility has been registered to ISO 9001:2008.

©2023 Alliance Laundry Systems LLC.

UniMac® by Alliance Laundry Systems